

This Application Note applies to the Unidrive M Series

## Starting up the Unidrive M100/101

This application note will describe how to startup a Unidrive M100/101 in open loop by defaulting the drive, programming the drive, performing an autotune, and finally running the motor.

### Keypad Functions Application Note M700 Demo

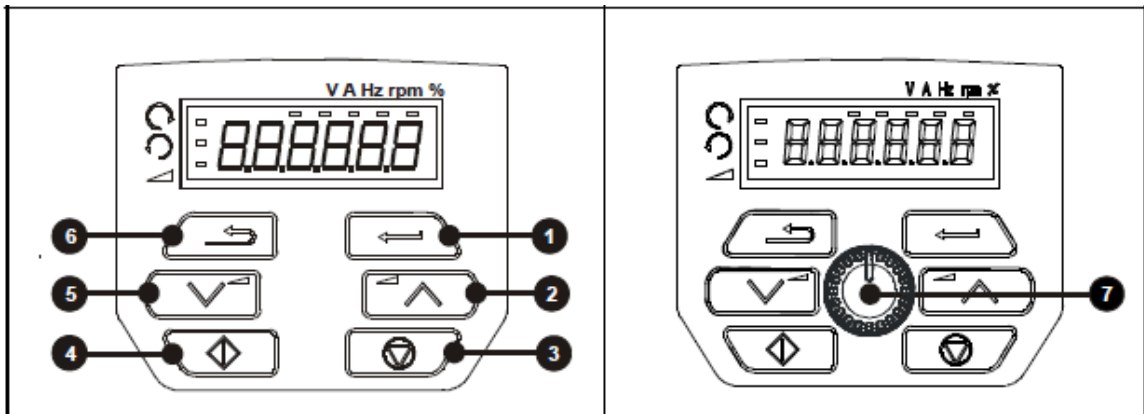

- (1) The Enter button is used to enter parameter view or edit mode, or to accept a parameter edit.
- (2 / 5) The Navigation keys can be used to select individual parameters or to edit parameter values.
- (3) The Stop / Reset key is used to stop and reset the drive in keypad mode. It can also be used to reset the drive in terminal mode.
- (4) The Start key is used to start the drive in keypad mode.
- (6) The Escape key is used to exit from the parameter edit / view mode.
- (7) The Speed ref pot is used to control the speed reference in keypad mode (only on Unidrive M101).

AN0009  
Rev-04 20Nov17

## Defaulting the Drive

Proceed to default the drive using the following steps:

1. Disable the drive by opening any connections between Terminal 9 and 11. The display will read "inh" indicating an "inhibited" state.
2. Press the ENTER button (1). The display should read "Pr. 10" or some two digit value after the prefix. Press the UP (2) or DOWN (5) button to arrive at "Pr. 00." Press ENTER (1) again.
3. The display should show a value of "NonE." Press ENTER (1) to make this value flash.
4. Press UP (2) eleven times to reach "dEF.60." This is the 60Hz defaults trigger. Hit ENTER.
5. Press the STOP/RESET (3) button. The display should go back to NonE when the drive's 60 Hz default settings were loaded successfully.



NOTE: If commissioning in a 50 Hz power supply region, choose "dEF.50" in step 4.

## Setting Up the Drive

Every Unidrive M100 or M101 has a label that shows the top 10 parameters to change in order to achieve basic control of a motor using this drive. Emphasis is placed on parameters 06, 07, and 08, which require information that would come from the motor nameplate.

Parameter 10 determines how much access is allowed for all of the drive's parameters. Whenever this parameter is set to a value of "ALL," the keypad display switches from the typical "Pr. 00" format to a "00.000" format. This other format is the standard display for drives prior to firmware update v01.05.00.00. In this display, either side of the decimal point may blink, indicating that the user should set either the Menu (00.000) or the Parameter (00.000). For example, a display of "00.009" is said to be in "Menu 0, Parameter 9." In order to access advanced parameters, a user would edit the Menu side of the display, press ENTER, and then edit the Parameter side.

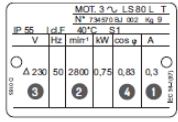
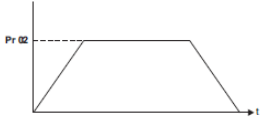
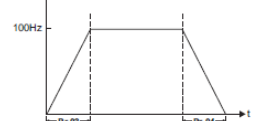

Next, follow the procedure discussed in Chapter 7 of the Control User Guide, shown below.

Action	Detail	
Before power-up	Ensure: <ul style="list-style-type: none"> <li>The drive enable signal is not given, terminal 11 is open.</li> <li>Run signal is not given, terminal 12/13 is open.</li> <li>Motor is connected to the drive.</li> <li>The motor connection is correct for the drive <math>\Delta</math> or <math>\Delta</math></li> <li>The correct supply voltage is connected to the drive.</li> </ul>	
Power-up the drive	Ensure: <ul style="list-style-type: none"> <li>Drive displays 'inh' (enable terminal is open).</li> </ul> If the drive trips, see Chapter 11 <i>Diagnostics</i> on page 80.	
Enter motor nameplate details	<ol style="list-style-type: none"> <li>Motor rated current in Pr 06 (Amps)</li> <li>Motor rated speed in Pr 07 (rpm / min<sup>-1</sup>)</li> <li>Motor rated voltage in Pr 08 (Volts)</li> <li>Motor rated power factor (cos <math>\phi</math>) in Pr 09</li> </ol>	
Set maximum speed	Enter: <ul style="list-style-type: none"> <li>Maximum speed in Pr 02 (Hz)</li> </ul>	
Set acceleration / deceleration rates	Enter: <ul style="list-style-type: none"> <li>Acceleration rate in Pr 03 (s/100 Hz)</li> <li>Deceleration rate in Pr 04 (s/100 Hz) (If braking resistor is installed, set Pr 28 = FAST. Also ensure Pr 10.030 and Pr 10.031 and Pr 10.061 are set correctly, otherwise premature 'lt.br' trips may be seen).</li> </ul>	

NOTE: Some motors do not have a power factor listed on their nameplate. In this situation, leave Pr. 09 (or 00.009) to its default value. Remember that the service factor (S.F.) is not the same as the power factor of the motor.

## Autotune

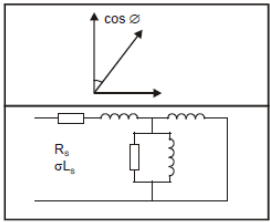
For commissioning an uncoupled, unloaded (nothing attached to the shaft) motor, a rotating autotune is recommended. Otherwise, performing a static autotune instead would be the better tuning option. Some applications may prohibit any form of autotuning such as running multiple motors with one drive. In such cases, ignore this section. Follow the autotune procedure described below. Pay attention to the last two bullet points.

Autotune	<p>The drive is able to perform either a stationary or a rotating autotune. The motor must be at a standstill before an autotune is enabled. A rotating autotune should be used whenever possible so the measured value of power factor of the motor is used by the drive.</p> <div style="border: 1px solid black; padding: 5px; margin-bottom: 10px;">  <p><b>WARNING</b> A rotating autotune will cause the motor to accelerate up to <math>\frac{2}{3}</math> base speed in the direction selected regardless of the reference provided. Once complete the motor will coast to a stop. The enable signal must be removed before the drive can be made to run at the required reference. The drive can be stopped at any time by removing the run signal or removing the drive enable.</p> </div> <ul style="list-style-type: none"> <li>A stationary autotune can be used when the motor is loaded and it is not possible to uncouple the load from the motor shaft. A stationary autotune measures the stator resistance of the motor and the dead time compensation for the drive. These are required for good performance in vector control modes. A stationary autotune does not measure the power factor of the motor so the value on the motor nameplate must be entered into Pr <b>09</b>.</li> <li>A rotating autotune should only be used if the motor is uncoupled. A rotating autotune first performs a stationary autotune before rotating the motor at <math>\frac{2}{3}</math> base speed in the direction selected. The rotating autotune measures the power factor of the motor.</li> </ul> <p>To perform an autotune:</p> <ul style="list-style-type: none"> <li>Set Pr <b>38</b> = 1 for a stationary autotune or set Pr <b>38</b> = 2 for a rotating autotune</li> <li>Close the Drive Enable signal (apply +24 V to terminal 11). The drive will display 'rdy'.</li> <li>Give a run command (apply +24 V to terminal 12 - Run forward or terminal 13 - Run reverse on Unidrive M100; press keypad start button on M101). The display will flash 'tuning' while the drive is performing the autotune.</li> <li>Wait for the drive to display 'inh' and for the motor to come to a standstill.</li> </ul> <p>If the drive trips, see Chapter 11 <i>Diagnostics</i> on page 80.</p> <ul style="list-style-type: none"> <li>Remove the drive enable and run signal from the drive.</li> </ul>	
Save parameters	<p>Select 'Save' in Pr <b>00</b> or Pr <b>mm.000</b> (alternatively enter a value of 1001) and press the red  reset button.</p>	
Run	<p>Drive is now ready to run</p>	

## Running the Motor

Once the drive parameters have been saved, the drive will need to have its Drive Enable and Run Forward (or Run) commands activated in order for the drive to transition into a Run state. The drive expects an electrical connection between terminals 9 and 11 to enable the drive. In order to provide a run command, the drive must receive it from either the drive terminal strip or the keypad. An LED will display below the Hz symbol and next to a clockwise arrow to indicate that the drive is in Run mode.

The following is a list of terminal configurations from Chapter 6 of the Control User Guide. Diagrams showing a **highlighted** header indicate the standard terminal configuration for drives with firmware no older than v01.05.00.00, standardizing two-wire (non-latching) start/stop control for all regions. For interest in the former USA region default configuration, ignore these **Standard two-wire** diagrams. For more information, check upgrade note UN0009.

## Terminal Configurations

The following are recommended wiring configurations for the different values of Pr. 05 (00.005).

### Pr. 05 = AV

Main Setting: Analog Input 1 in terminal 2 is set for an analog voltage reference (0-10Vdc).  
 Secondary: Start/Stop set for two-wire (non-latching) control in terminals 11 and 12. Terminal 13 set for a Run Reverse. Digital Output on terminal 10 set for the Zero Frequency flag.

#### Standard two-wire

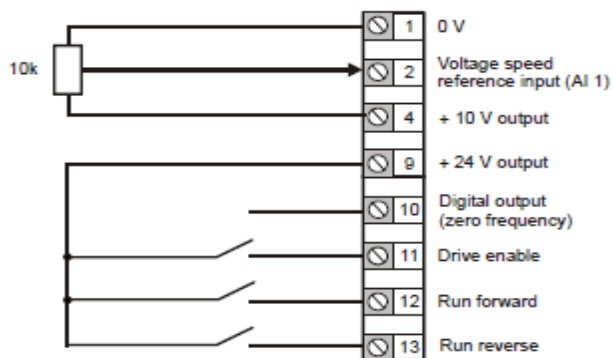

#### Legacy (60Hz) three-wire

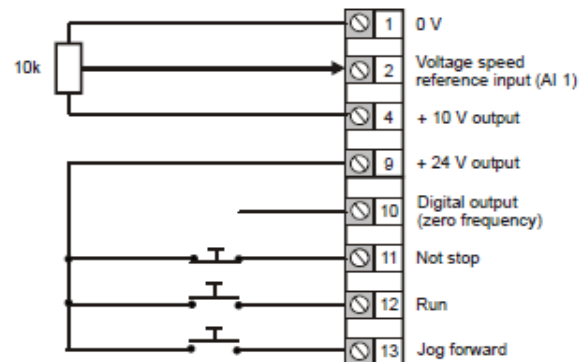

### Pr. 05 = AI

Main Setting: Analog Input 1 in terminal 2 is set for an analog current reference (4-20mA).  
 Secondary: Start/Stop set for two-wire (non-latching) control in terminals 11 and 12. Terminal 13 set for a Run Reverse. Digital Output on terminal 10 set for the Zero Frequency flag.

#### Standard two-wire

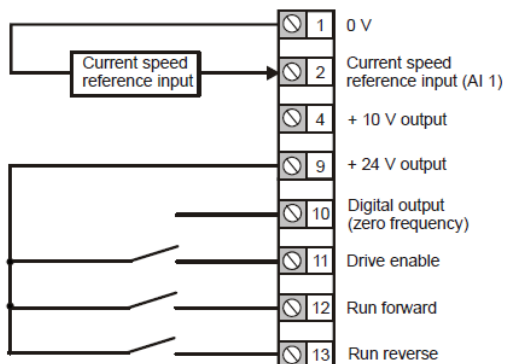

#### Legacy (60Hz) three-wire

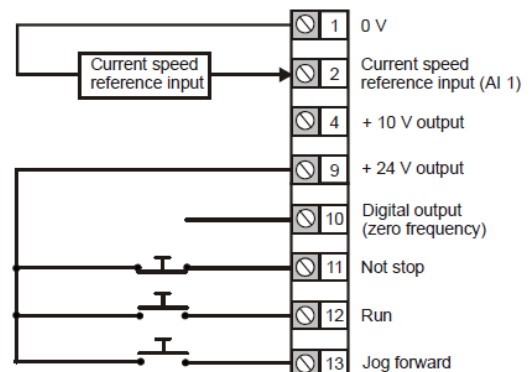

### Pr. 05 = AV.Pr

Main Setting: Analog Input 1 in terminal 2 is set for an analog voltage reference (0-10Vdc). Terminal 10 is set as a digital input and works together with Terminal 13 to toggle between three Preset Speeds or the Analog Reference.

Secondary: Preset Speeds 2, 3, 4 will need to be defined in Pr. 19, 20, 21 respectively.

#### Standard two-wire

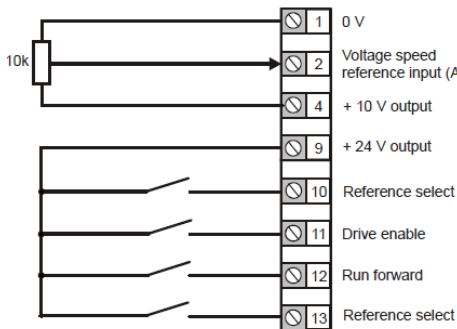

Terminal 10	Terminal 13	Reference selected
0	0	Analog reference 1*
0	1	Preset speed 2*
1	0	Preset speed 3*
1	1	Preset speed 4*

#### Legacy (60Hz) three-wire

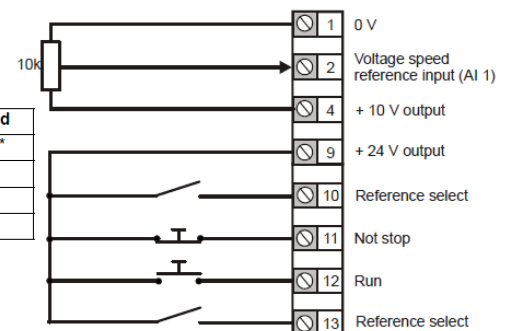

### Pr. 05 = AI.Pr

Main Setting: Analog Input 1 in terminal 2 is set for an analog current reference (4-20mA). Terminal 10 is set as a digital input and works together with Terminal 13 to toggle between three Preset Speeds or the Analog Reference.

Secondary: Preset Speeds 2, 3, 4 will need to be defined in Pr. 19, 20, 21 respectively.

#### Standard two-wire

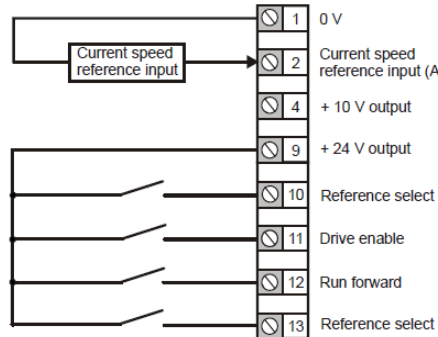

Terminal 10	Terminal 13	Reference selected
0	0	Analog reference 1*
0	1	Preset speed 2*
1	0	Preset speed 3*
1	1	Preset speed 4*

#### Legacy (60Hz) three-wire

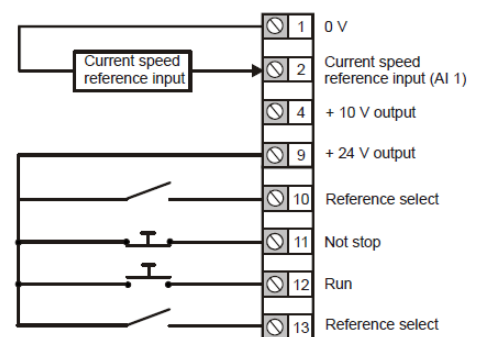

### Pr. 05 = PrESEt

Main Setting: Terminal 10 is set as a digital input and works together with Terminal 13 to toggle between four Preset Speeds.  
 Secondary: Preset Speeds 1, 2, 3, 4 will need to be defined in Pr. 18, 19, 20, 21 respectively.

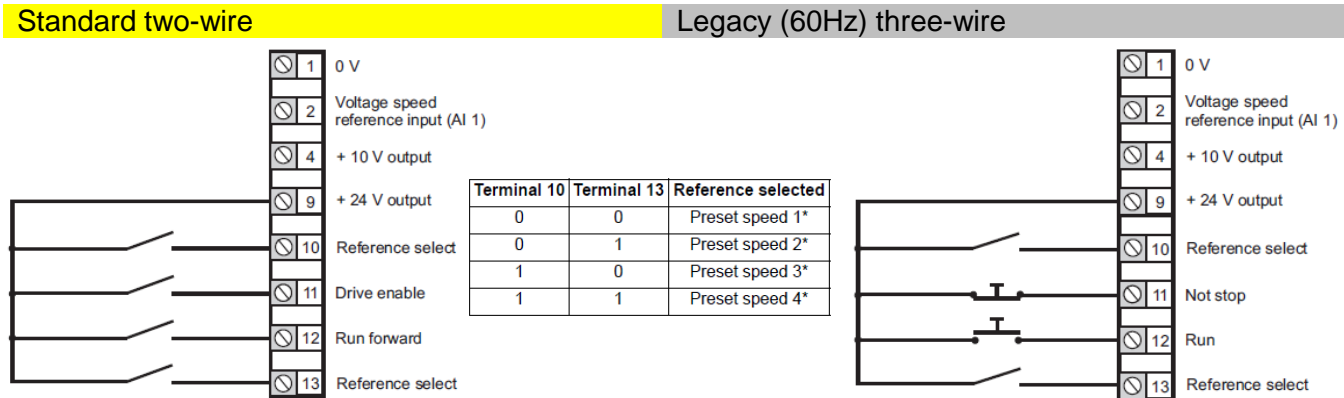

### Pr. 05 = PAd

Main Setting: Speed reference defined by the Keypad Reference, using the UP and DOWN keypad buttons. Start/Stop is controlled by the green (START) and red (STOP) keypad buttons.

Secondary: Still need connection from terminal 9 to terminal 11 to enable drive. Terminal 10 set as a digital output to indicate the Zero Frequency flag.

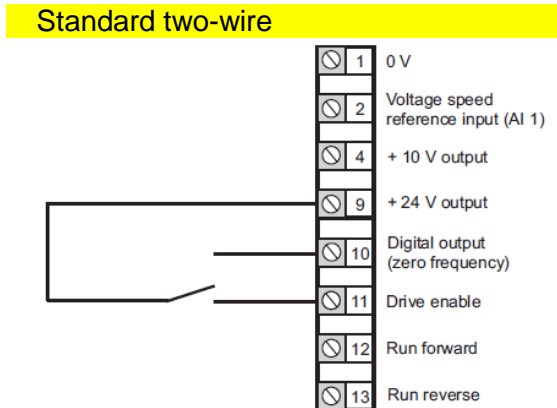

Standard two-wire

**Pr. 05 = PAd.rEF**

Main Setting: Speed reference defined by the Keypad Reference, using the UP and DOWN keypad buttons. Start/stop is defined by drive terminal 12, drive enable on terminal 11.

Secondary: Terminal 13 set as a Run Reverse command. Terminal 10 set as a digital output to indicate the Zero Frequency flag.

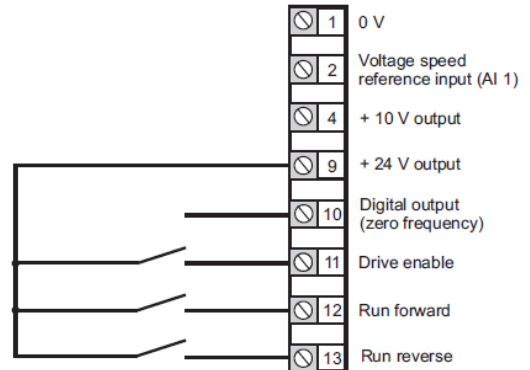

**Pr. 05 = torquE**

Main Setting: Analog Input 1 is set to receive an analog voltage signals (0-10Vdc) to define a torque reference. The drive's keypad UP and DOWN button are set to control a speed reference. Terminal 13 is set to toggle between running in torque mode (use the torque reference) or running in speed mode (use the speed reference). Reference not being used is ignored.

Secondary: Start/Stop using terminal 12, drive enable with terminal 11. *Due to a bug on the torquE macro, will need to set advanced parameter 01.014 = PAd.rEF (6).*

Standard two-wire      Legacy (60Hz) three-wire

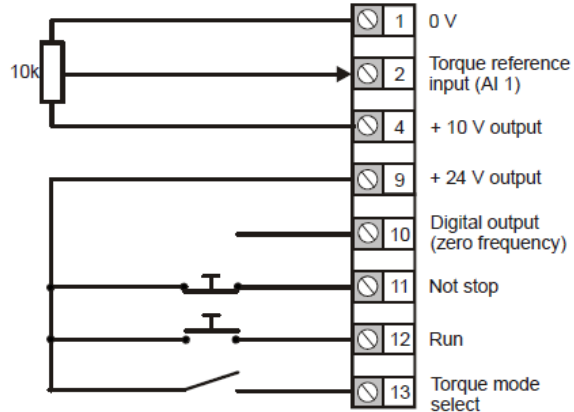
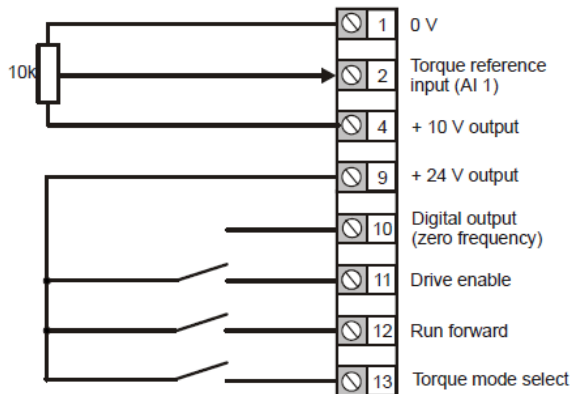

NOTE: The PAd and PAd.rEF configurations were always set for two-wire (non-latching) start/stop before and after firmware update v01.05.00.00.

**Conclusions**

It is important to consider the different wiring configurations available in Pr. 05 (00.005) as templates. These configurations can always be changed manually after completing a change to Pr. 05. A quick way to switch between the (now) standard two-wire start/stop logic control to the legacy three-wire





→ All for dreams

control is to change Pr. 11 (00.011) from either a value of “0” or “4.” For older drives (before v01.05.00.00), 00.011 won’t appear, the same procedure needs to be carried through in 06.004, choose either the value “0” for two-wire or “4” for three-wire.

**Resources:** can be found on our website: [www.controltechniques.com](http://www.controltechniques.com)

For help contact [techsupport.cta@mail.nidec.com](mailto:techsupport.cta@mail.nidec.com), or call Technical Support at 952-995-8000, 24/7/365